

REVISIONS				
ZONE	REV	DESCRIPTION	DATE	APPROVED
	100	INITIAL RELEASE ECN 115992	10/17/11	BC

NOTES: UNLESS OTHERWISE SPECIFIED

- INDICATED DIMENSIONS ARE FOR AN ARRAY SIZE OF 336x256.
- CONNECTOR INTERFACE: HIROSE 50 PIN DF12-50DS-0.5V(86). MATING CONNECTOR P/N DF12(5.0)-50DP-0.5V(86). FOR PIN-OUT DESIGNATIONS SEE TAU CAMERA USERS MANUAL.
- INDICATED TOLERANCES APPLY TO CAMERA MOUNTING SURFACES ONLY. OTHER SURFACES ARE CAST AND HAVE DRAFT.
- INDICATED ALLOWABLE TRAVEL FOR FOCUS.
- CAMERA WEIGHT NO LENS: 50.5 GRAMS, LENS WEIGHT, 13mm-f1.25: 19.6 GRAMS
TOTAL CAMERA WEIGHT: 70.1 GRAMS

D

C

B

A

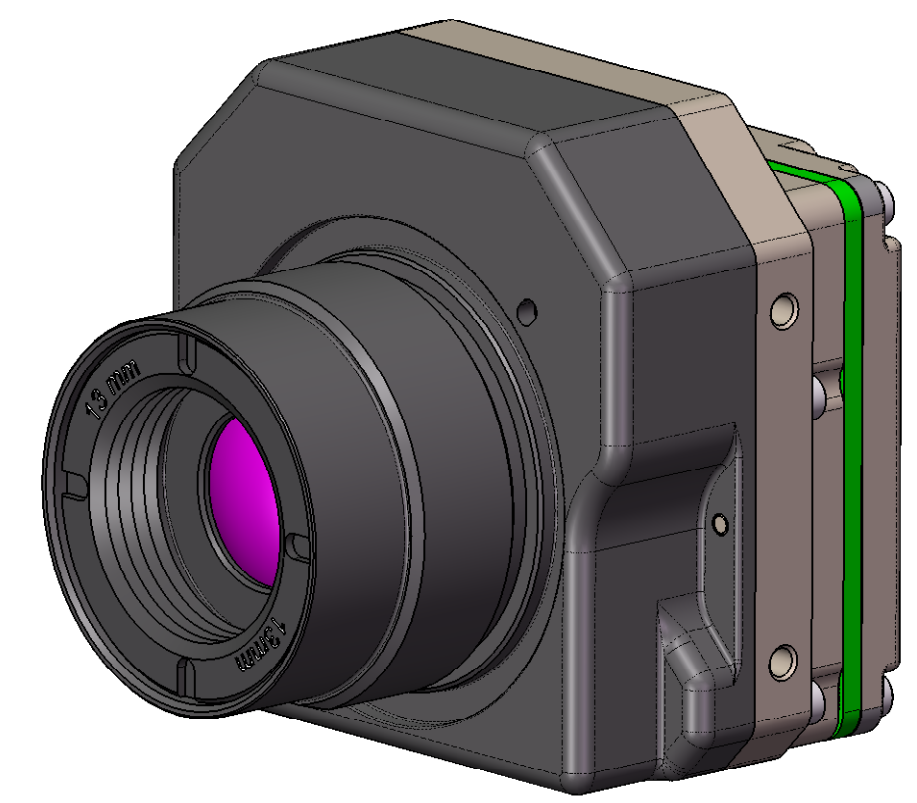
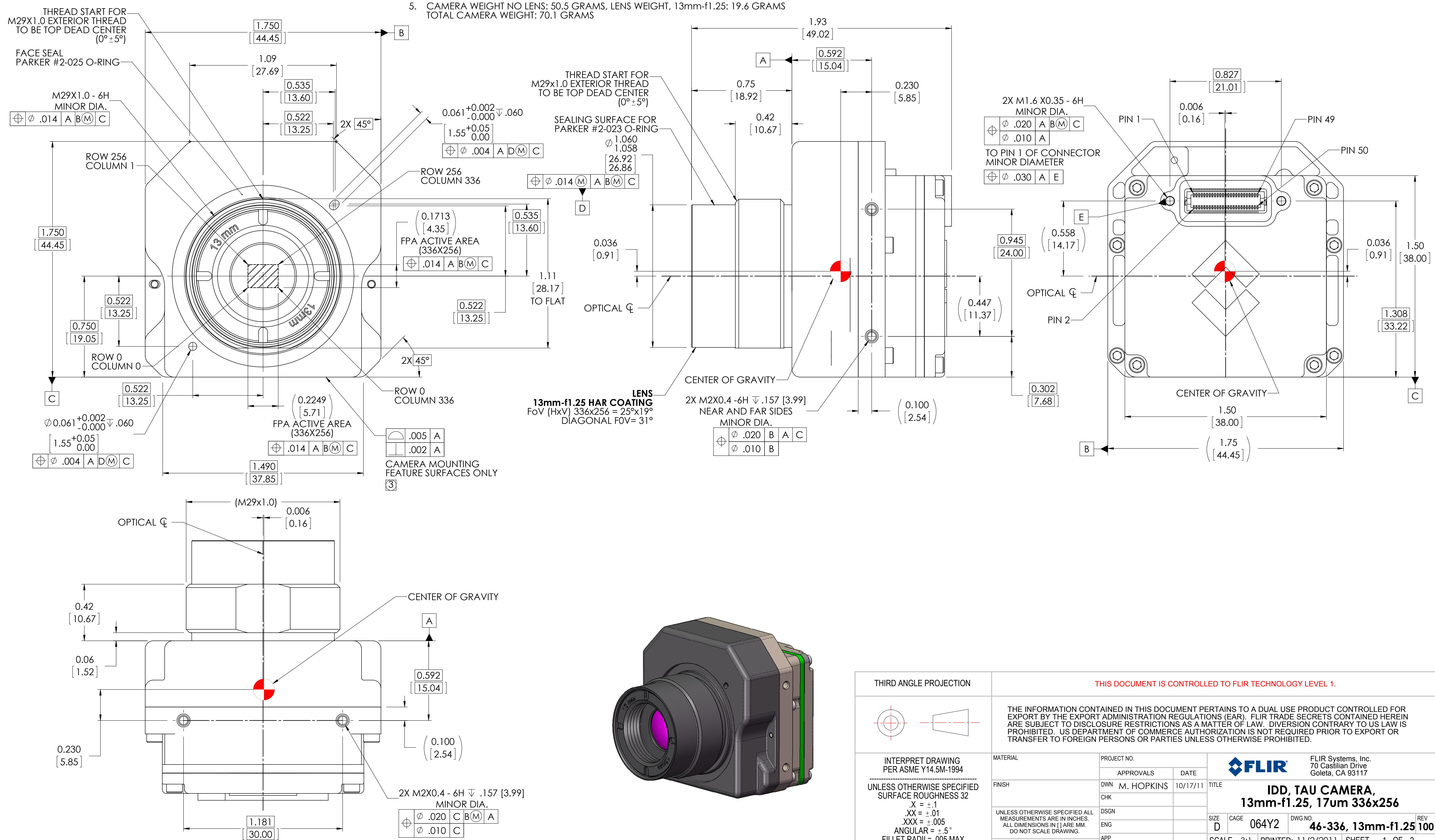

THIRD ANGLE PROJECTION		THIS DOCUMENT IS CONTROLLED TO FLIR TECHNOLOGY LEVEL 1.			
		THE INFORMATION CONTAINED IN THIS DOCUMENT PERTAINS TO A DUAL USE PRODUCT CONTROLLED FOR EXPORT BY THE EXPORT ADMINISTRATION REGULATIONS (EAR). FLIR TRADE SECRETS CONTAINED HEREIN ARE SUBJECT TO DISCLOSURE RESTRICTIONS AS A MATTER OF LAW. DIVERSION CONTRARY TO US LAW IS PROHIBITED. US DEPARTMENT OF COMMERCE AUTHORIZATION IS NOT REQUIRED PRIOR TO EXPORT OR TRANSFER TO FOREIGN PERSONS OR PARTIES UNLESS OTHERWISE PROHIBITED.			
INTERPRET DRAWING PER ASME Y14.5M-1994 UNLESS OTHERWISE SPECIFIED SURFACE ROUGHNESS 32 X = ±.1 .XX = ±.01 .XXX = ±.005 ANGULAR = ±.5° FILLET RADII = .005 MAX	MATERIAL	PROJECT NO.	FLIR Systems, Inc. 70 Castilian Drive Goleta, CA 93117		
	FINISH	APPROVALS	DATE	TITLE IDD, TAU CAMERA, 13mm-f1.25, 17um 336x256	
UNLESS OTHERWISE SPECIFIED ALL MEASUREMENTS ARE IN INCHES. ALL DIMENSIONS IN [] ARE MM. DO NOT SCALE DRAWING.	UNLESS OTHERWISE SPECIFIED ALL MEASUREMENTS ARE IN INCHES. ALL DIMENSIONS IN [] ARE MM. DO NOT SCALE DRAWING.	DSGN	SIZE	CAGE	DWG NO.
	CALC WT: 70.10 GRAMS	APP	D	064Y2	46-336, 13mm-f1.25 100
		SCALE	3:1	PRINTED: 11/2/2011	SHEET 1 OF 2

D

C

B

A

DWG NO. 46-336, 13mm-f1.25 SH 1 REV 100

D

D

C

C

B

B

A

A

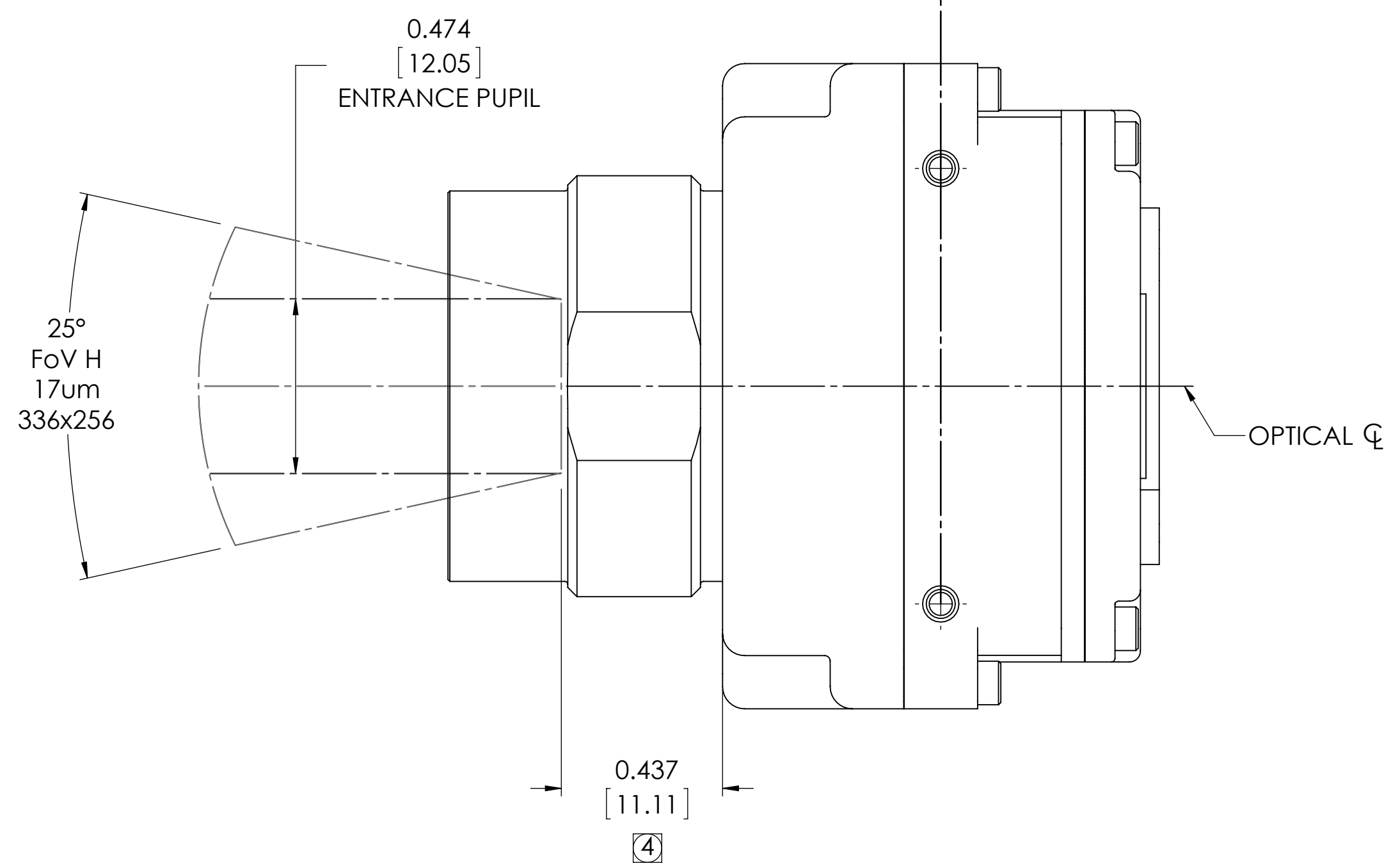
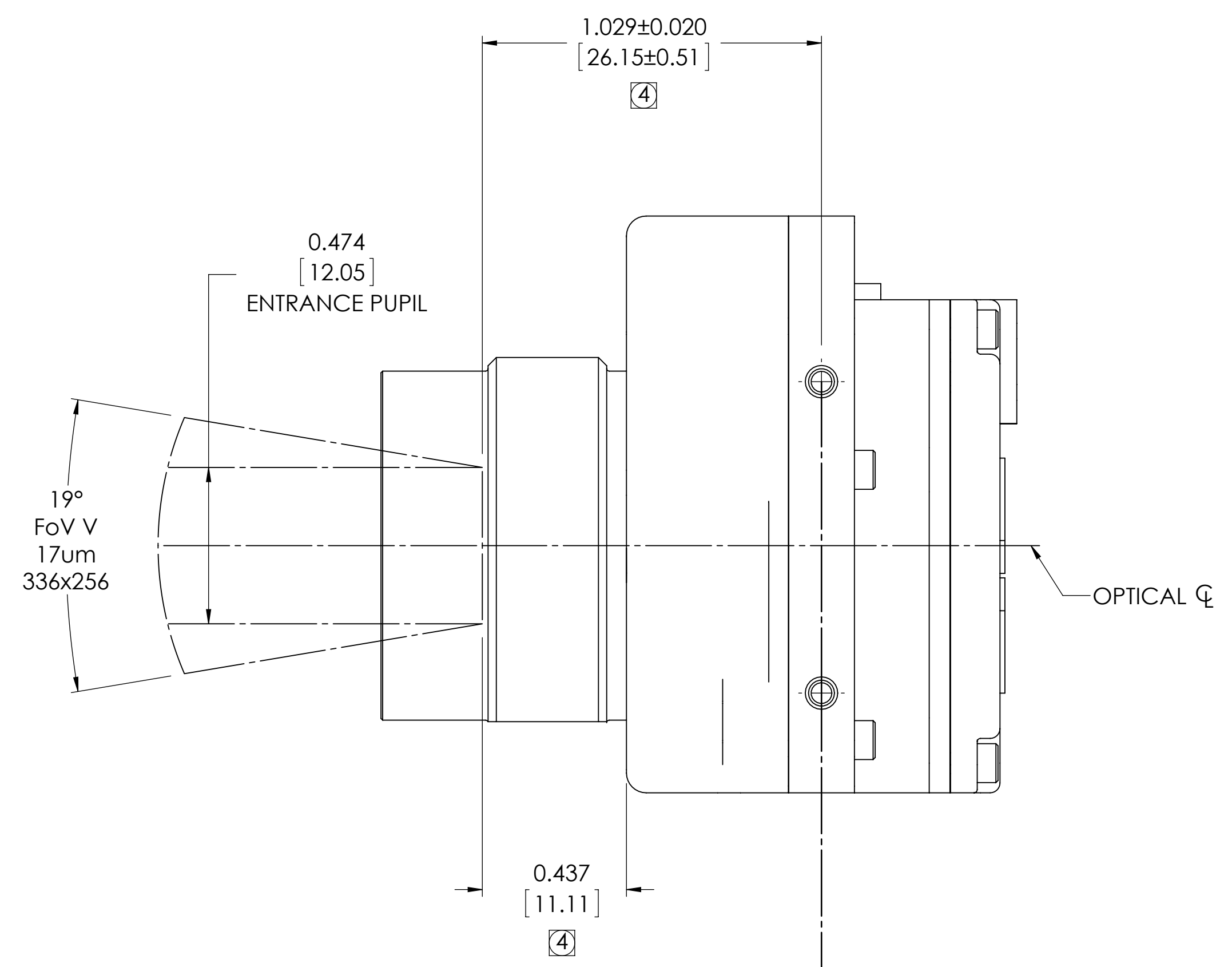

13 mm-f1.25
336x 256 ARRAY

IDD, TAU CAMERA,
13mm-f1.25, 17um 336x256

SIZE	CAGE	DWG NO.	REV
D	064Y2	46-336, 13mm-f1.25	100
SCALE 3:1		PRINTED: 11/2/2011	SHEET 2 OF 2
SOLIDWORKS MODEL: 46-Tau Camera Core MODEL REVISION: B-WC			

DWG NO. 46-336, 13mm-f1.25 SH 2 REV 100